

1999-2003 Ford F-150

PART #: SR65512TB

REALTRUCK BACKRACK

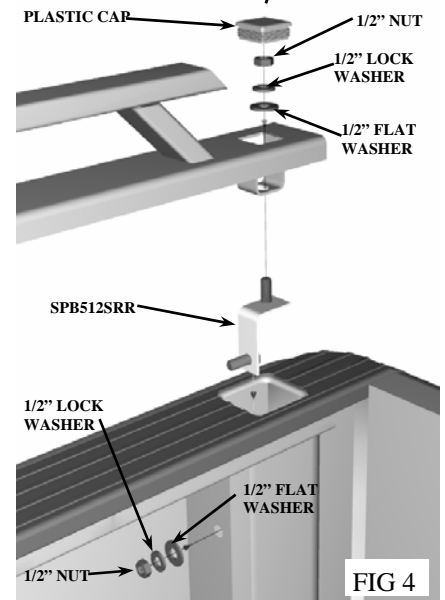
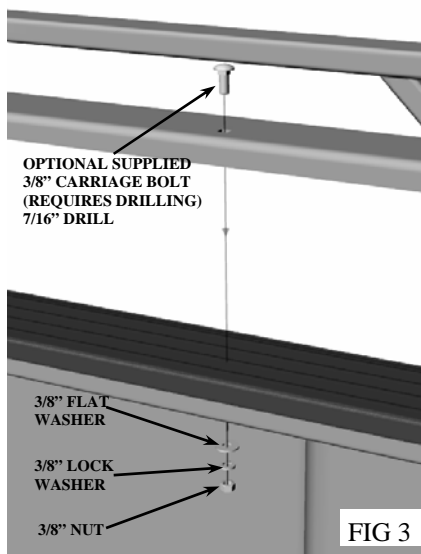
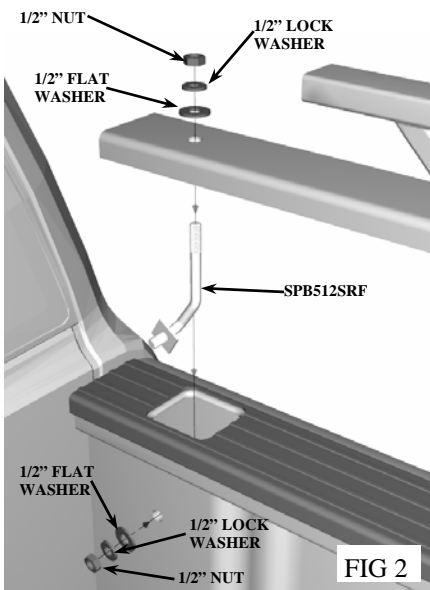
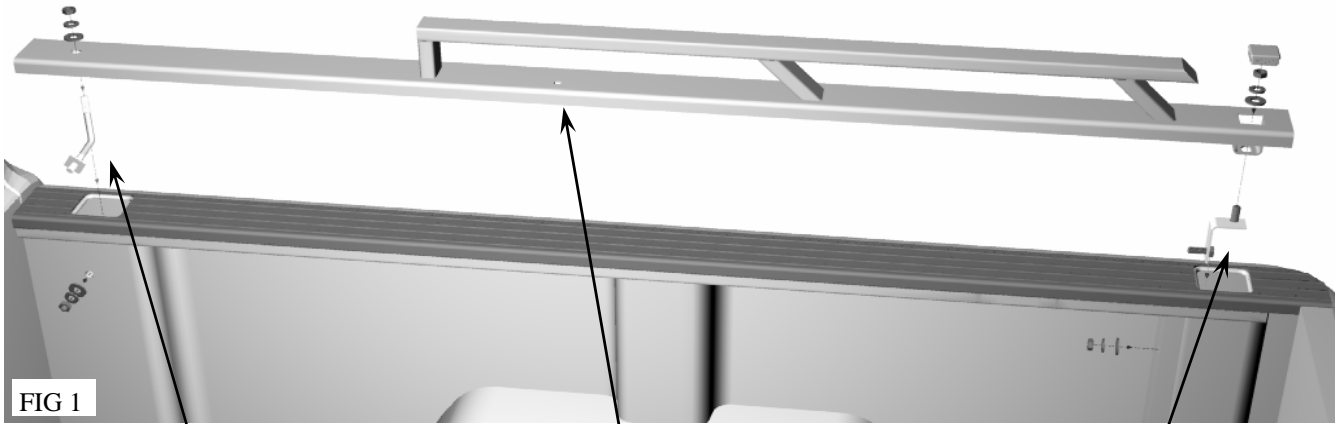

**FIG. 1 SIDERAIL
INSTALLATION**

TOOLS REQUIRED

9/16" WRENCH
3/4" WRENCH
15/16" WRENCH

7/16" DRILL BIT (OPTIONAL)
CORDLESS DRILL (OPTIONAL)

OPTIONAL BACKRACK

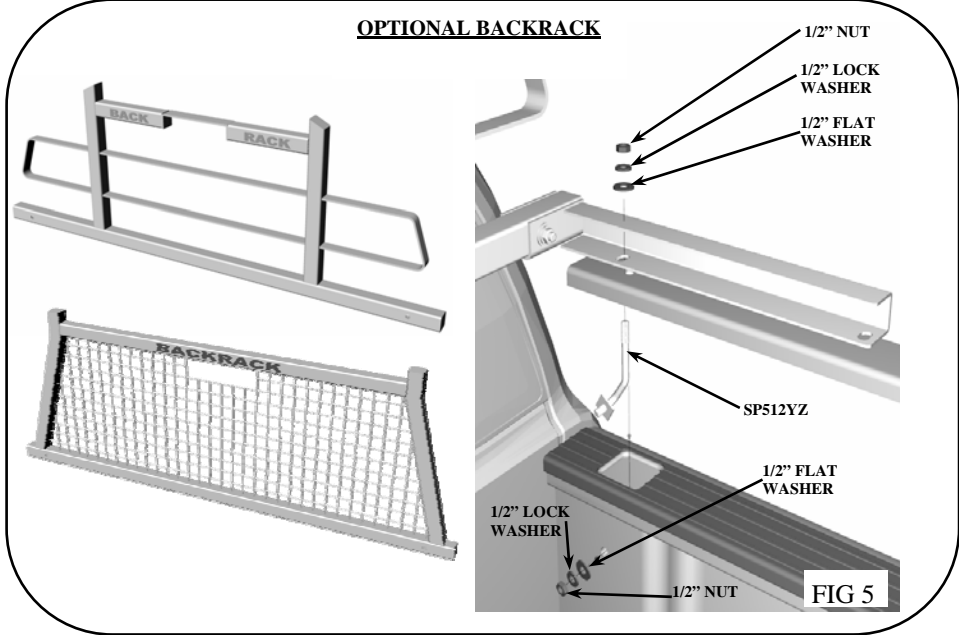

SR65512TB-0308 R2

1999-2003 Ford F-150

READ THIS NOW!

Your truck should look like the one shown aside. If you think you are missing any parts, think that this part number is not for your truck or have any installation question, call our customer service department at toll free 8888-588-6101 or locally 800-265-8137.

Other ways to reach RealTruck Backrack:

email: info@backrack.ca

Support@backrack.com



*****These instructions are for the RealTruck Backrack SIDERAIL with OR without an OPTIONAL RealTruck Backrack or SAFETYRACK*****

The RealTruck Backrack SIDERAIL is secured to your truck with Stake Pocket Bolts specifically designed for your make and model of truck. These bolts mount into each of the stake pockets. If your truck has a BEDLINER we suggest you remove it to install the Stake Pocket Bolts then reinstall prior to finishing with the new SIDERAIL.

IF YOU ARE INSTALLING A RealTruck Backrack WITH THIS SIDERAIL KIT, YOU WILL NEED THE FASTNERS INCLUDED WITH THE RealTruck Backrack—OPEN THE RealTruck Backrack FIRST, REMOVE THE HARDWARE AND PROCEED AS INSTRUCTED BELOW (SECTION B).

Section A: Installation SIDERAIL only

STEP 1: Install the stake pocket bolts.

- Insert SPB512SRF (picture on reverse, supplied with the SIDERAIL) into the two front stake pockets as outlined in Figure 2. Tighten all stake pocket bolts facing truck bed.
- Insert the SPB512SRR into the rear stake pocket (supplied with the SIDERAIL kit) and thread the 1/2" nut with washer and lock washer, tighten. See Figure 4

STEP 2: Install the SIDERAIL

- SIDERAIL should have the angle lip towards the inside of the truck box, with the name facing the outside of the truck. Lower the side rail into position, slowly, lining up the stake pocket bolts. SIDERAIL should drop into place with little effort. Do not hammer or force the SIDERAIL down on the truck bed. These have been designed to drop into the pockets of your truck with ease. If supplied, place the foam strips along the underside of the SIDERAIL to prevent scratching. See Figure 1.

STEP 3: Finish tightening the hardware

- Place remaining hardware, 1/2" nuts, washers and lock washers on the stake pocket bolts on the SIDERAIL, hand tighten.
- Once all the bolts are in place, tighten all fasteners. **DO NOT OVERTIGHTEN.** Use discretion.
- With a small piece of wood or soft mallet, install the plastic cover caps to finish off the rail installation.

Section B: Installation SIDERAIL and RealTruck Backrack

STEP 1: Install the stake pocket bolts.

- Insert SPB512YZ (picture on reverse) from the RealTruck Backrack hardware bag into the two front stake pockets as outlined in Figure 5. Thread the 3/4" nut with lock washer and washer onto the 3/4" stud of the stake pocket bolt. Tighten all stake pocket bolts facing truck bed. Discard the remaining HWB044 which will not be required, since the front stake pocket hardware will be used from the RealTruck Backrack.
- Follow preassembly instructions included with the RealTruck Backrack and continue with STEP 2 above.